

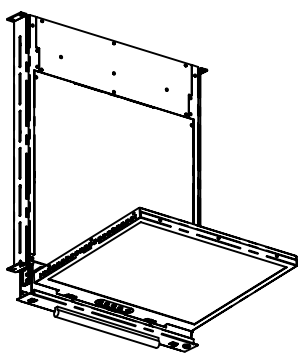

NO.	DESCRIPTION	DATE

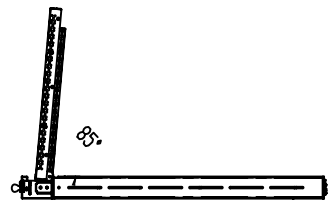
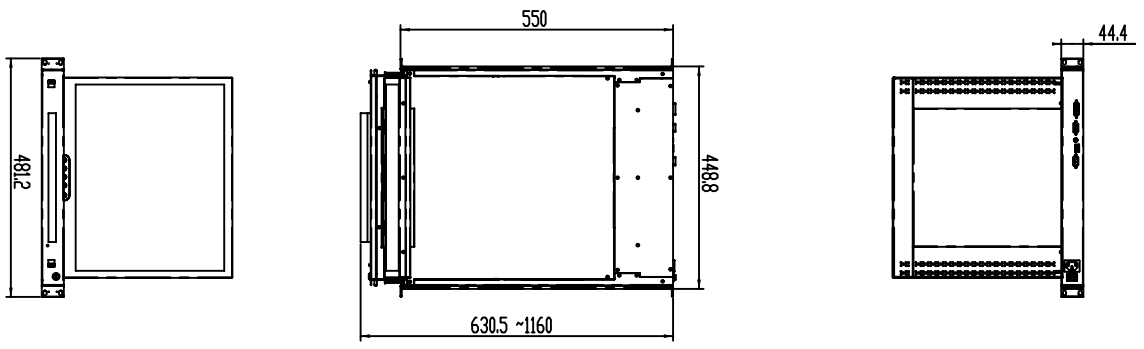

注意：  
所有工件必须倒毛刺，去接刀痕。

 13-11-07 13-11-07	TOL	30 120 315	30 120 315	40.1 40.5 40.2 40.3 40.5	UNIT : mm	FINISHING	PART NO.	Ver. A0
	ANGLE TOL	30 45	30 45	30 45	30 ANGLE	MATERIAL	IND. NO.	Rev. 1
DESIGNED	CHECKED	APPROVED	TITLE	SCALE	DATE	BY	SHEET	OF
			RMD-19-ASM	1/1	13-11-07		1	1