

1 2 3 4 5 6 7 8

A

B

C

D

E

F

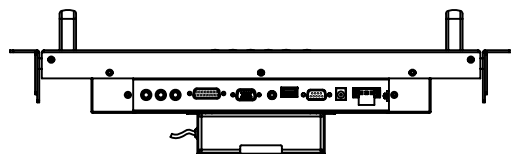
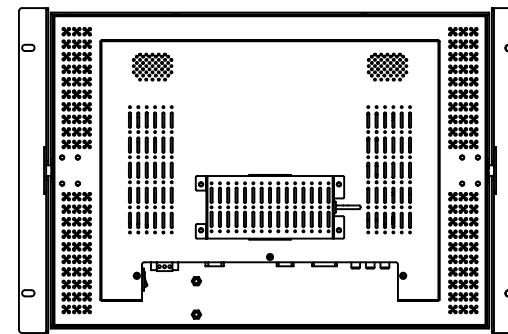
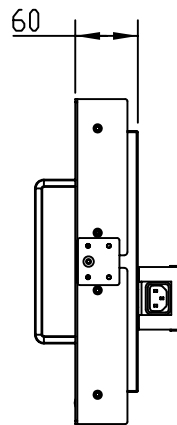
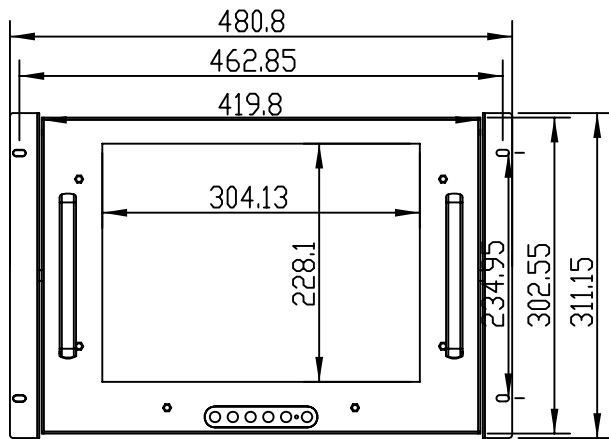
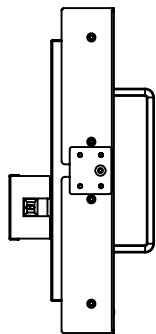
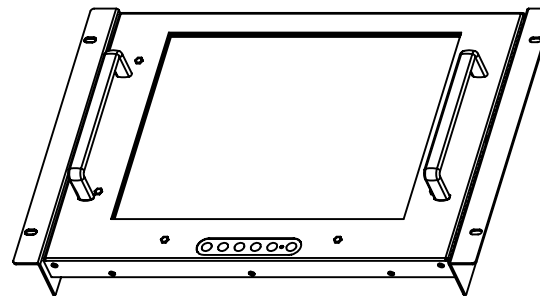
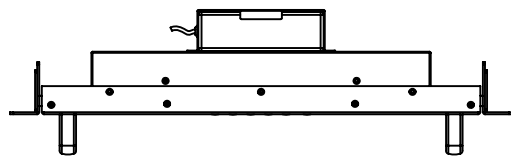

NOTE:

1. MATERIAL:
2. ALL BURRS MUST BE FILLETED TO <0.05mm
3. FINISH: COATING (SPEC. SEE SAMPLE)
4. TOLERANCE UNLESS OTHERWISE SPEC. SEE TOLERANCE TABLE

TOL	< 30	: ±0.1	UNIT : mm	FINISHING		PART NO.	Ver.	A0		
	30 < 120	: ±0.15					MOLD NO.	RMB-15	Qty	
	120 < 315	: ±0.2	3RD ANGLE'S	MATERIAL		TITLE	RMB-15-ASSY			
	315 <	: ±0.3	APPROVED	DESIGNED	LiuChunhua	2007.8.16	DRAWING NO.	3D3V.DWG		
	ANGLE TOL	: ±0.5°						DRAWN		SIZE



△			
△			
△			
MARK	DESCRIPTION	SING	DATE
1			
2			
3			
4			
5			
6			
7			
8			