

# → IPPC-1741

## 17" Industrial Panel PC



Open frame structure



With Aluminum front panel

### Features

- High performance PC up to Pentium 4
- 17" XGA TFT LCD
- Modularized system Design
- Resistive Touch screen (optional)

### Specification

#### system

- Board size: Mini-ITX (170X170mm)/ATX Mother board 9.6"X12"
- Intel® P4 Socket 478 / LGA775 processor up to 3.X Ghz
- Upgradable standard SDRAM / DDR memory
- System Fan: 2\* (60x60x10mm) cooling fan
- Speaker: 2\* 2W Stereo Speaker
- OSD : Brightness, Contrast, H/V Position, Color, Phase, Clock, Management
- Construction: Heavy duty steel & Aluminum (Front panel)
- Dimensions: (WxHxD) With front panel:450mm\*353mm\*137.7mm
- Dimensions: (WxHxD) W/O front panel:440mm\*343mm\*133 mm
- Dimensions: (WxHxD) With front panel:450mm\*353mm\*137.7mm

#### LCD

Display Type:	17" TFT LCD
Max Resolution	1280x 1024
Display Colors	16.2M colors
Light Luminance	300 cd/m <sup>2</sup>
Backlight MTBF	50,000 hrs
Pixel Pitch:	0.264*0.264mm
Contrast Ratio	450 : 1
Power consumption	25.8W

#### Storage

- 6 in 1 card reader (Left side)
- Interchangeable slim optical drive (Right side)
- 2.5" ATA / SATA high Capacity HDD (horizontal)

#### Environmental

- Operating temperature: 0°C to 60°C (32° F~ 140° F)
- Storage temperature: -20°C to 80°C (-68° F~ 176° F)
- Storage humidity: 10% to 90% non-condensing
- Vibration: 17 to 500HZ 1G PTP
- Shock: 1G/peak(11m sec)
- Front panel protection: meet Nema4&IP65(IPPC)

#### Power Supply

- INPUT: 115~230 VAC, 50/60Hz
- OUTPUT: 250W with PFC +5V@25A,+12V@13A  
+3.3V@20A

#### Mounting

- Wall-mount/Desktop stand/swing arm
- Meets standard VESA (75/100mm) mounting



## ANNSO TECHNOLOGY CO., LTD

Factory address: Hexi District of JinXia, Chang'an Town, Dongguan City, Guangdong, China.  
Tel: +86-769-5387700 5387755 5305389 5305396 5531482 5530279 Fax: +86-769-5329662



## Dimension Diagram

Unit:mm

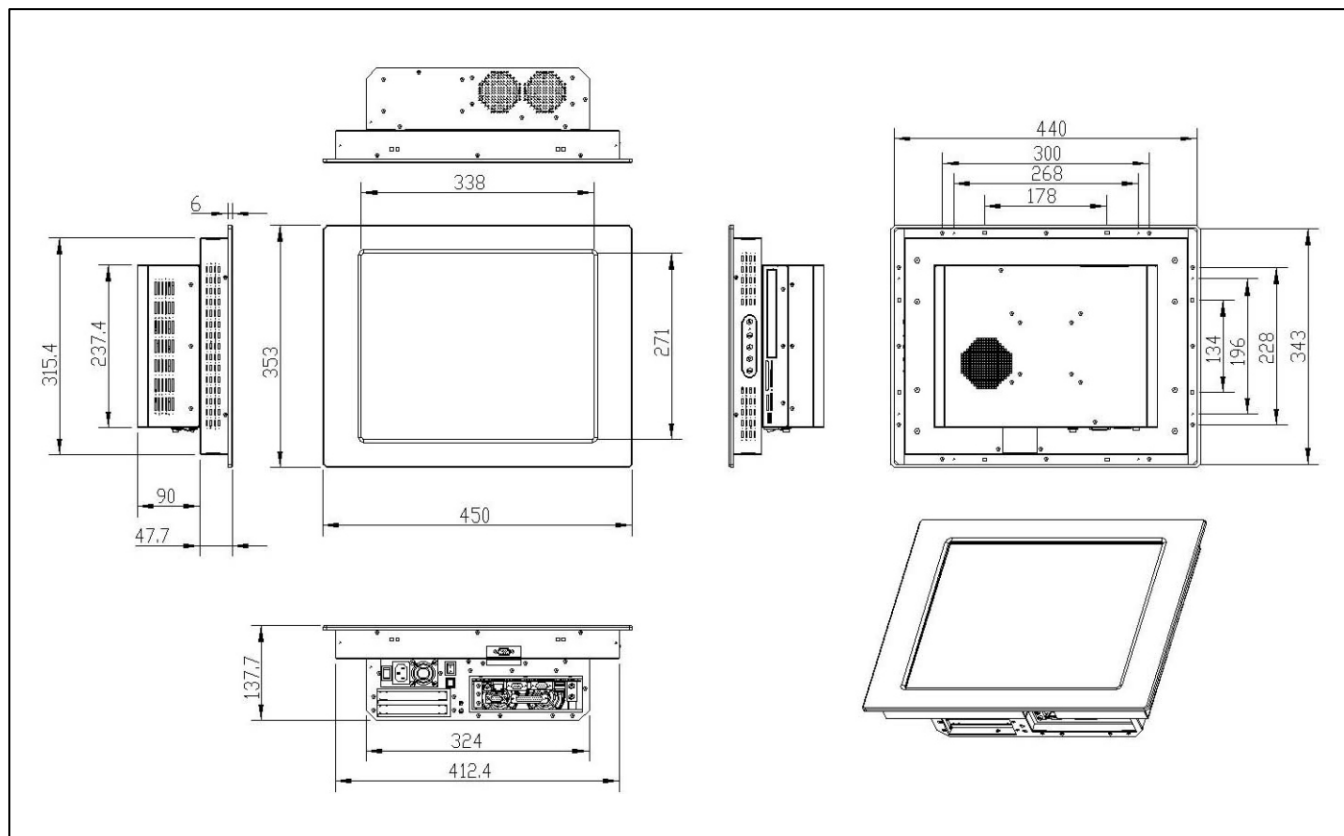

## Ordering Information

- IPPC-1741** Industrial Panel PC with 17" TFT LCD and 250W power supply.
- IPPC-1741T** Industrial Panel PC with 17" TFT LCD, Touch screen and 250W power supply.
- OPPC-1741** Open frame Industrial Panel PC with 17" TFT LCD and 250W power supply.
- OPPC-1741T** Open frame Industrial Panel PC with 17" TFT LCD, Touch screen and 250W power supply.