

M4 TAP are just only for front mount

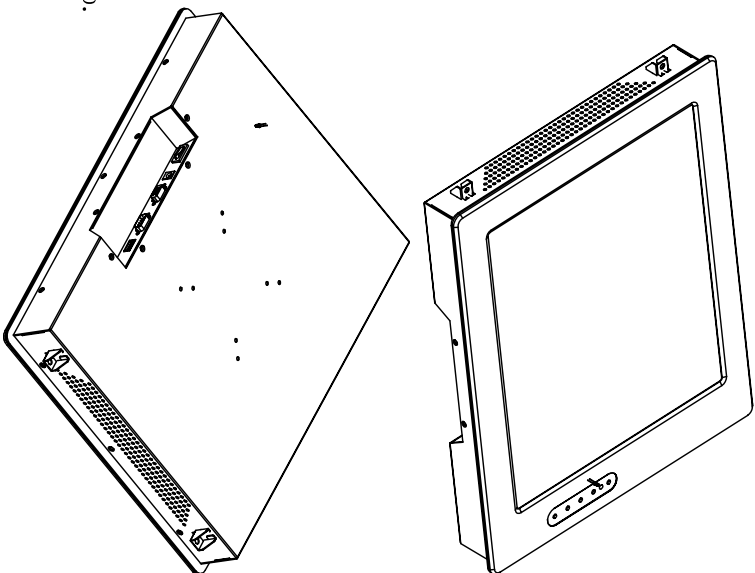

NOTE:

1. ALL BURS MUST BE FILLED TO (0.05mm)
2. FINISH COATING (SPEC. SEE SAMPLE)
3. TOLERANCE UNLESS OTHERWISE SPEC. SEE TOLERANCE TABLE

TDL	30 120 315	< < <	30 120 315	±0.1 ±0.15 ±0.2 ±0.3	UNIT : mm	FINISHING	MOLD Name	Ver.
ANGLE TDL	±0.5°				3RD ANGLES	MATERIAL	MOLD NO.	1P4-17
						APPROVED	PART NO.	1P4-17-455V
						CHECKED	TITLE	
						DESIGNED	DRAWING NO.	1P4-17-303V
						DRAWN	SIZE	A4
							SCALE	02
							SHEET	1 OF 1



MARK	DESCRIPTION	SING	DATE
△			
△			
△			

1 2 3 4 5 6 7 8