

RMB-20

19" Rack mount 20.1" TFT LCD monitor

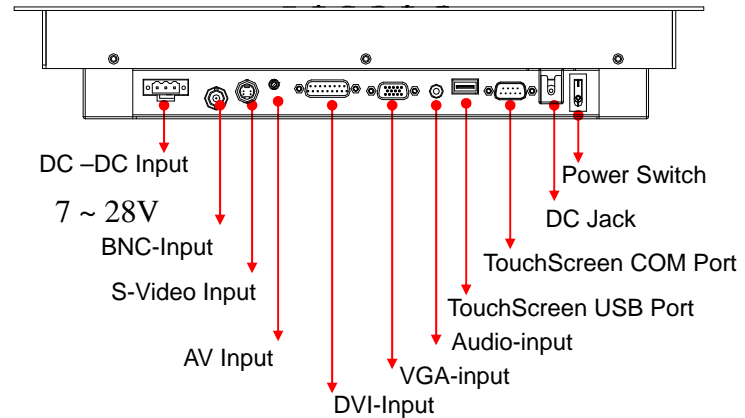

Mechanical Design Drawings

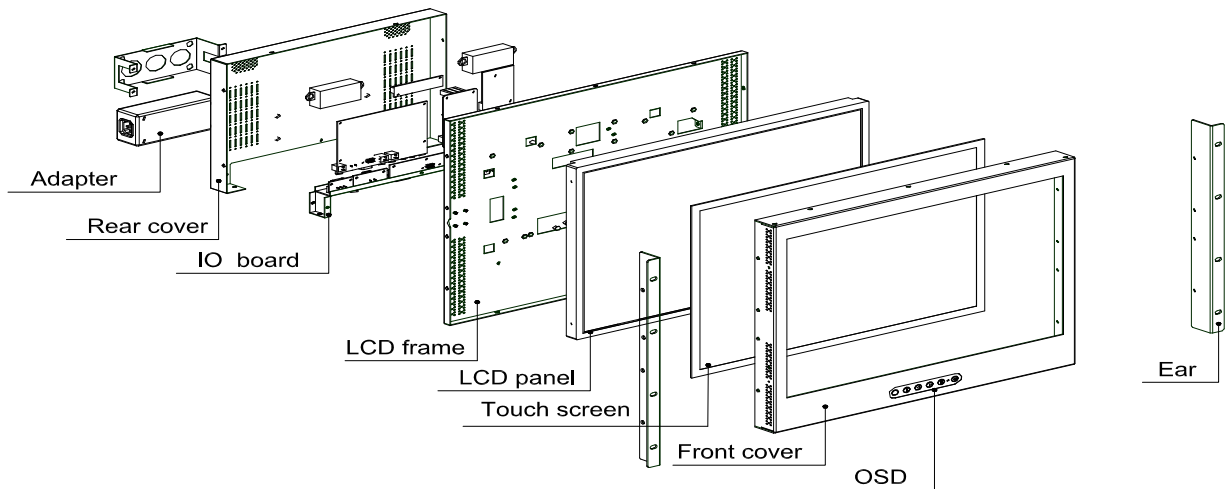

System

- Compact 19" Rack mount TFT LCD monitor, 9U High
- Input signal: VGA + DVI + Audio , AV IN (optional)
- Control: Front panel OSD Control
- Power Supply: External 60W DC 12V power adapter
DC 7V-28V wide range input (optional)
- OS Support: MS DOS, Windows 98/SE, Windows NT4.0, Windows 2000, Windows XP
- Dimensions (W x H x D): 482.6 x 399.2 x 63.5 mm
- Packing Dimension: 610 x 510 x 195
- NET weight: Gross weight:
- Signal Connector: VGA (15 Pin D-SUB) + DVI (DVI-D Connector) + audio input (audio jack) , AV connector (optional) AV input (s-video, RCA, BNC)
- Function Control: Power Switch, Menu, Select (+,-), Auto
- OSD: Brightness, Contrast, H/V Position, Color, Phase, Clock, Management

- Touch screen (optional)
- Speaker : 2x2 W Stereo internal speaker

LCD

- Display Type : 20.1" SXGA+ TFT LCD
- Resolution : 1400 x 1050
- Max.color : 16.7M
- Luminance : 300 cd/m²
- View Angel : 170°(H) , 160°(V)
- Pixel Pitch : 0.2916 x 0.2916 mm
- Contrast Ratio : 1000 : 1
- Response Time : 5.3 ms
- Power Consumption : 21.73 W
- LCD MTBF : 50,000hrs

Annso Technology Co.,Ltd

Factory address: The south faces industry area of Xia Gang Fu Hai road, Chang'an Town, Dongguan City, Guangdong, China.

Tel: +86-769-81666360 81666395/96/97

Fax: +86-769-81666306.

Web: www.annso.com www.annso.com.cn www.medianice.com Email: Sales@annso.com.cn



Touchscreen(optional)

- Internal USB or RS-232 interface controller
- Type: Surface Acoustic Wave touch
- Touch Resolution: Above 2048 x 2048
- Light transmission: 90% or more
- Surface hardness : 7H
- Response TimeMax: 50ms
- Life expectancy : 50 Million
- Operation system : Window 98 / 2000 / ME / XP / NT / CE, DOS , Linux

Environmental

- Operating temperature: 0°C to 45°C (32°F ~ 113°F)
- Storage temperature:-20°C to 60°C (-4°F ~ 140°F)
- Storage humidity: 10% to 95%@ 40°C ,non-condensing,
- Vibration: 10 ~ 190Hz, 0.19mm 10 cycles 1G
- Shock: 30G peak acceleration (11 msec. duration)

Ordering Information

RMB-20	20.1" TFT LCD, 60W DC 12V Power Adapter
RMB-20T	20.1" TFT LCD, Surface Acoustic Wave Touchscreen, 60W DC 12V Power Adapter
RMB-20A	20.1" TFT LCD, 60W DC 12V Power Adapter , w / AV IN Connector
RMB-20TA	20.1" TFT LCD, Surface Acoustic Wave Touchscreen, 60W DC 12V Power Adapter , w / AV IN Connector
RMB-20-DC	20.1" TFT LCD, DC 7-28V IN Power Module
RMB-20T-DC	20.1" TFT LCD, Surface Acoustic Wave Touchscreen, DC 7-28V IN Power Module
RMB-20A-DC	20.1" TFT LCD, DC 7-28V IN Power Module, w / AV IN Connector
RMB-20TA-DC	20.1" TFT LCD, Surface Acoustic Wave Touchscreen, DC 7-28V IN Power Module , w / AV IN Connector

Dimension Diagram

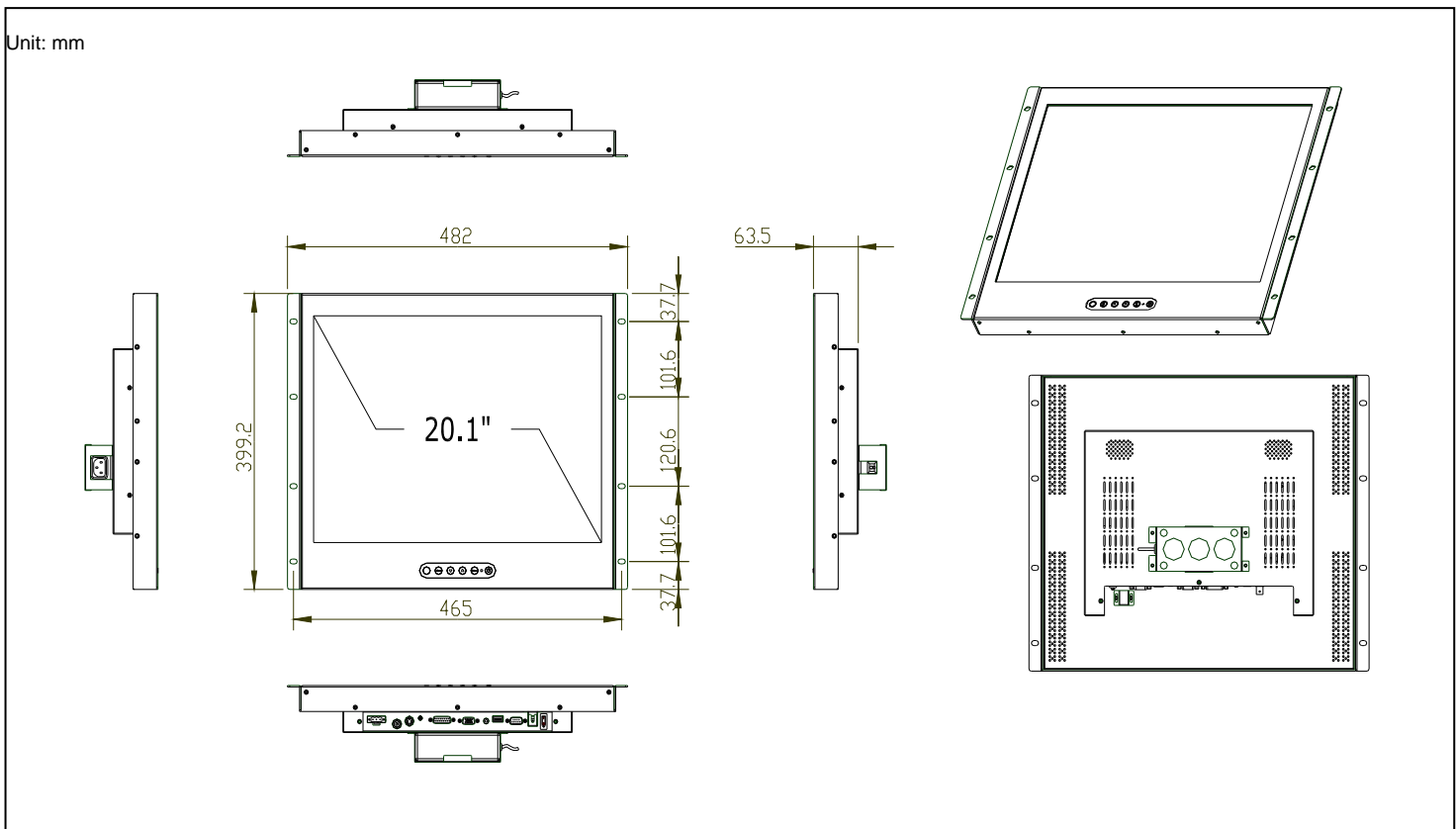

Annso Technology Co.,Ltd

Factory address: The south faces industry area of Xia Gang Fu Hai road, Chang'an Town, Dongguan City, Guangdong, China.

Tel: +86-769-81666360 81666395/96/97

Fax: +86-769-81666306.

Web: www.annso.com www.annso.com.cn www.medianice.com Email: Sales@annso.com.cn

