



15" Panel Mount Full Function Industrial Panel PC

IPPC-2715

Features

- On board Intel Atom N270 (1.6GHz) Processor
- 1 x PCI expansion slot , 1x mini PCI-E
- Space for 1 x 2.5" HDD, 1 x slim optical driver
- Analog resistive touch screen (option)
- Front panel NEMA 4/IP65 compliant
- OSD control keys to optimized the display
- Front hardness glass protect screen
- Build in 2 x 2 Watts stereo speaker
- Standard VESA 75/100mm support wall mount and swing arm
- AC 100~240V wide range power input

Design Drawings

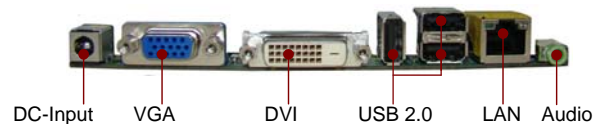
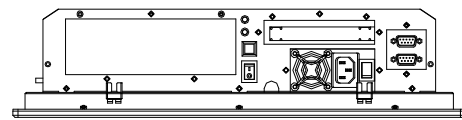
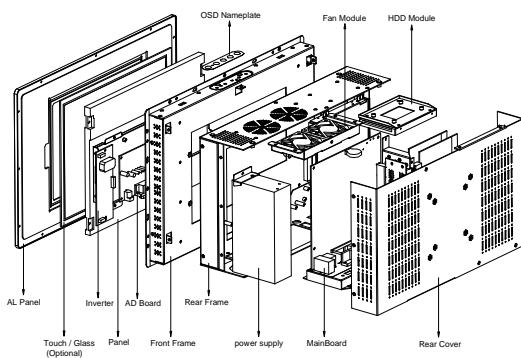

★ Unit : mm

Specifications

TFT characteristics

Display Type	: 15" XGA TFT LCD
Screen resolution (Pixels)	: 1024 x 768
Brightness	: 250cd/m2
Contrast Ratio	: 700 : 1
Pixel Size	: 0.297*0.297
Max Color	: 16.2MB
Viewing angle	: 150° (H) , 135° (V)
Response Time	: 8 ms
LCD MTBF	: 50,000hrs

Available Options

Touch Screen	: Resistive
Wireless LAN	: Meet IEEE802.11b/g standard
Open frame structure	: without front bezel

Mechanical and Environmental

Construction	: Heavy duty steel and aluminum front panel
Operating temperature	: 32 °F~113 °F (0 °C to 45°C)
Storage temperature	: -4 °F~140 °F (-20 °C to 60 °C)
Storage humidity	: 10% to 90% non-condensing
Vibration	: 17 to 500HZ 1G PTP
Shock	: 1G /peak (11m sec)
Dimensions (WXHxD)	: 436 x 313 x 104 mm
Weight	: Net: 9.5 kg, Gross: 11.5 kg

System Characteristics

Processor	: on board Intel Atom N270 (1.6GHz) processor with 533MHz FSB
Chipset	: Intel 945GSE+ ICH7M
Memory	: 1x 200pin SODIMM, Max.2GB DDR2 533/667/800MHz
Graphic	: Intel GMA950 (224M shared)
Storage	: Space for 1x 2.5" HDD (SATA)
Optical device	: Space for slim type CDROM/DVDROM/Combo (DVD+CDRW)DVD±RW
Ethernet	: 1 x Giga Lan
VGA port	: 1 x VGA Connector (reserved for LCD screen)
DVI port	: 1 x DVI connector
Audio	: Realtek ALC662 build in 2x 2 watts stereo speaker
USB Port	: 3 x USB 2.0
Serial Port	: 2 x RS-232
Expansive Slot	: 1 x PCI , 1x mini PCI-E

Power Specifications

Input	: 100~240V AC, 50/60Hz
Output	: ATX 150W with active PFC +5V@ 13 A, +12V@ 16A

Certification and Approvals

- CE/FCC/ROHS



15" Panel Mount Full Function Industrial Panel PC

IPPC-2715

Ordering Information

IPPC-2715 -150X : 15" Intel Atom N270 1.6 GHz Industrial Panel PC, with 150W Power Supply

IPPC-2715T -150X : 15" Intel Atom N270 1.6 GHz Industrial Panel PC, with 150W Power Supply and resistive touch screen

Design Drawings

Front IP65 compliant

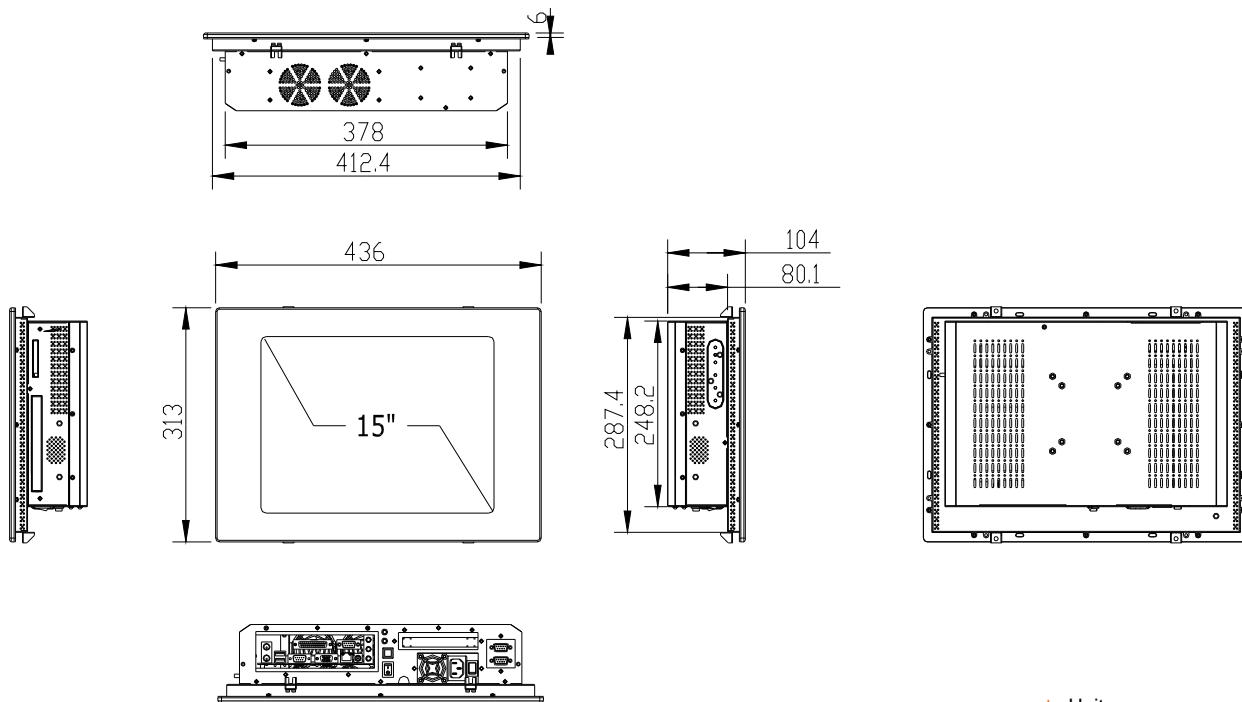

15" Panel Mount Full Function Industrial Panel PC

OPPC-2715

Ordering Information

OPPC-2715-150X : 15" Intel Atom N270 1.6GHz open frame Industrial Panel PC, with 150W Power Supply

OPPC-2715-150X : 15" Intel Atom N270 1.6GHz open frame Industrial Panel PC, with 150W Power Supply and resistive touch screen

Design Drawings

Open Frame

* Unit : mm